

125LB SALT SPREADER







ASSEMBLY AND OPERATION INSTRUCTIONS

SAVE THESE INSTRUCTIONS FOR FUTURE REFERENCE

Table of Contents

Hazard Signal Word Definitions.....	3
Controls and Features Identification.....	4
Component & Hardware.....	5, 6
Assembly Instructions	7, 8, 9
Operation Instructions	10, 11
Spreading Instructions.....	12, 13
Maintenance and Storage	14
Specification.....	14
Parts Drawing & Parts List	15, 16

Hazard Signal Word Definitions

	<p>This is the safety alert symbol. It is used to alert you to potential personal injury hazards. Obey all safety messages that follow this symbol to avoid possible injury .</p>
	<p>DANGER indicates an imminently hazardous situation which, if not avoided, will result in serious injury.</p>
	<p>WARNING indicates a potentially hazardous situation which, if not avoided, could result in serious injury.</p>
	<p>CAUTION indicates a potentially hazardous situation which, if not avoided, may result in minor or moderate injury.</p>
	<p>CAUTION used without the safety alert symbol indicates a potentially hazardous situation which, if not avoided, may result in property damage.</p>

ABOUT YOUR SALT SPREADER

This salt spreader is designed to spread a wide range of materials (Rock Salt, Ice Melt, Sand, Seed Mulch and large-size granular material). Materials such as Powders, Manure, Top Soil, and Gravel have the wrong physical characteristics and should not be used with this spreader. Never exceed the rated load capacity of 125lbs when operating the spreader.

Your spreader needs to be pushed at three miles per hour, which is a brisk walking speed. Slower or faster speeds will change the spread patterns. Wet spreading material will also change the spread pattern and flow rate. Clean your spreader thoroughly after each use. Wash between the shut off plate and bottom of the hopper.

Technical specifications on the push spreader are provided in the “Specifications” section of this manual.

Controls and Features Identification

Read this owner's manual before operating the equipment. Familiarize yourself with the location and function of the controls and features. Save this manual for future reference.



- 1) **T-Handle** – Pushes and moves the spreader easily.
- 2) **Hopper** – Do not exceed rated load capacity 125lb.
- 3) **3-Flap Deflector Shields** – Controls spreading pattern around sidewalks and near sensitive foliage.
- 4) **Impeller** - Evenly distributes material.
- 5) **Tires / Wheel** – Do not exceed recommended rated 30PSI.
- 6) **Flow Control** – Controls the flow of material being spread.

CAUTION

Read and follow all instructions for assembly and operation. Failure to properly assemble this equipment could result in serious injury to the user or bystanders, or cause equipment damage.

SALT SPREADER COMPONENT PARTS AND ASSEMBLY

Take all parts out of the packaging and inspect components to ensure there are no missing pieces before starting to assemble the push spreader follow steps 1 through 3.

TOOLS REQUIRED

- Pliers (2 Each)
- 10mm Wrenches (2 Each)
- 13mm Wench

Component Parts

#24 Bolt M6X60
1 PC



#40 Bolt M6X35
2 PCS



#47 Bolt M6X20
4 PCS



#11 Lock Nut M8
2 PCS



#9 Lock Nut M6
7 PCS



#19 Wheel Bushing
2 PCS

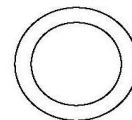

#17 Flat Washer ϕ 16

1 PC

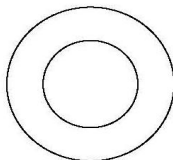

#12 Flat Washer ϕ 8

2 PCS



#55 Spring Washer ϕ 6

6 PCS



#16 Cotter Pin ϕ 5X35

1 PC

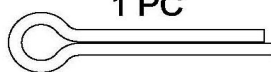

Component Parts

Main Assembly

1 PC

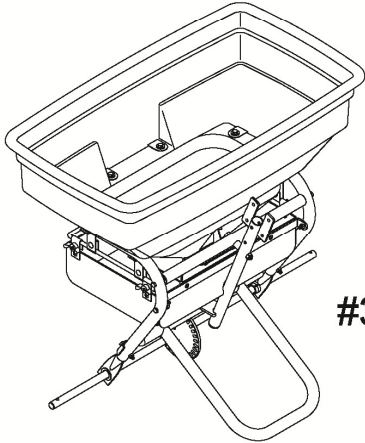

#44 Rain Cover

1 PC

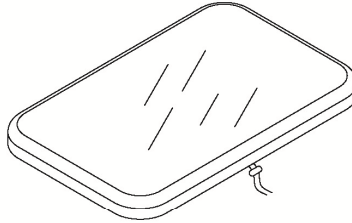

Handle Assembly

1 PC

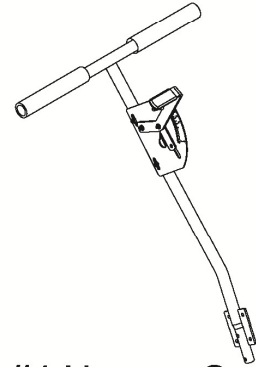

#34 Connecting Rod

1 PC



#15 Pneumatic Wheel

2 PCS



#4 Hopper Screen

1 PC



Assembly Instructions

STEP 1: Attaching the Wheels

1. When assembling the wheels make sure the air valves are facing outward.
2. Slide the wheel bushing (#19) onto the left side of the axle.
3. Push one wheel (#15) onto the axle. Align the hole in the axle and wheel and insert the M6x60 bolt (#24) and secure with a M6 lock nut (#9).
4. Slide the other wheel bushing (#19) onto the right side of the axle.
5. Push the wheel (#15) onto the axle. Slip the Ø16 flat washer (#17) and insert the Ø5x35 cotter pin (#16) into the hole and fasten it by bending.

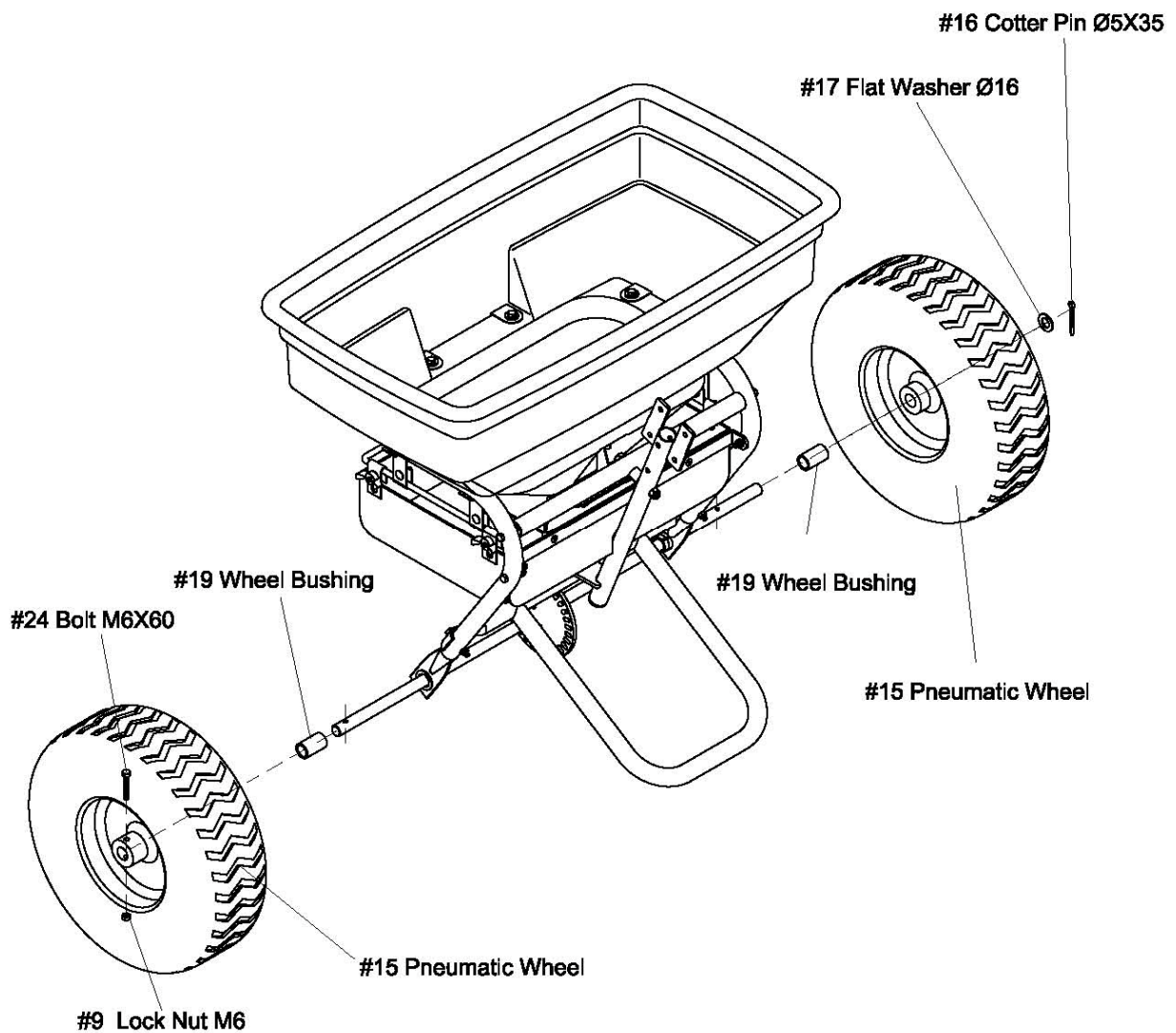

STEP 2: Attach Handle to the Supporting Leg

1. Insert handle assembly into the supporting leg (#39). In the center holes put two M6x35 bolts (#40), Ø6 spring washer (#55) and secure with M6 lock nut (#9).
2. On the outer holes of the handle assembly and supporting leg (#39) put four M6x20 bolts (#47), Ø6 spring washers (#55) and secure with M6 lock nuts (#9).

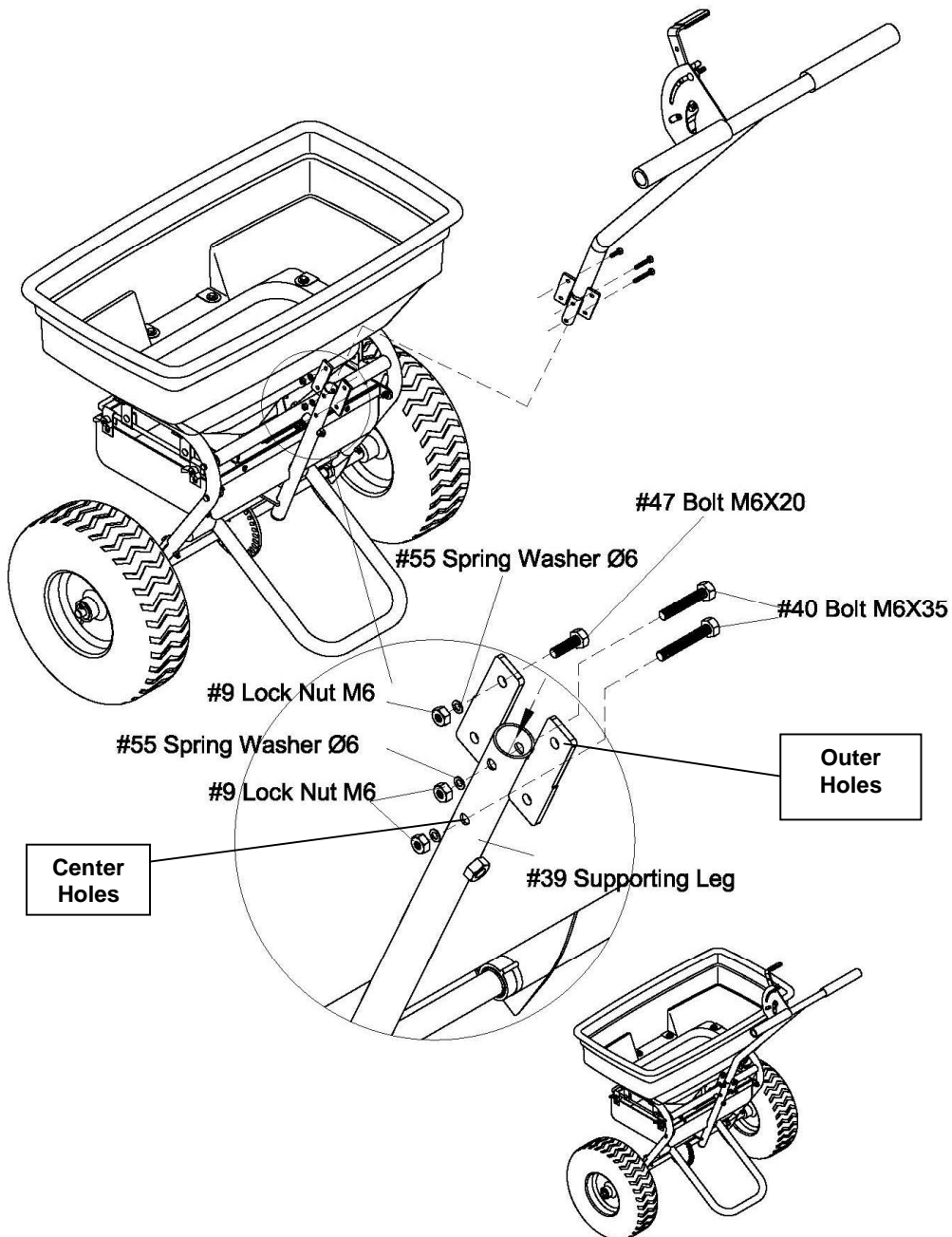

STEP 3: Connecting the Solid Linkage

1. Push the flow control handle to the “30” position. Insert the A end of the connecting rod (#34) through the Ø8 flat washer (#12) and into the hole on the gauge level plate (#46). Secure with a M8 lock nut (#11).
2. Insert the B end of the connecting rod (#34) through the Ø8 flat washer (#12) and into the hole on the fixed plate (#13). Secure with M8 lock nut (#11).
3. Push the control handle to the “0” position. The hole in the bottom of the spreader should be completely closed. If the flow control handle position and the hole in the bottom of the hopper does match exactly, loosen the two bottom M6 lock nuts (#9) and move the gauge level plate until the handle position and the hole in the bottom of the hopper match. Re-tighten the two M6 lock nuts (#9).

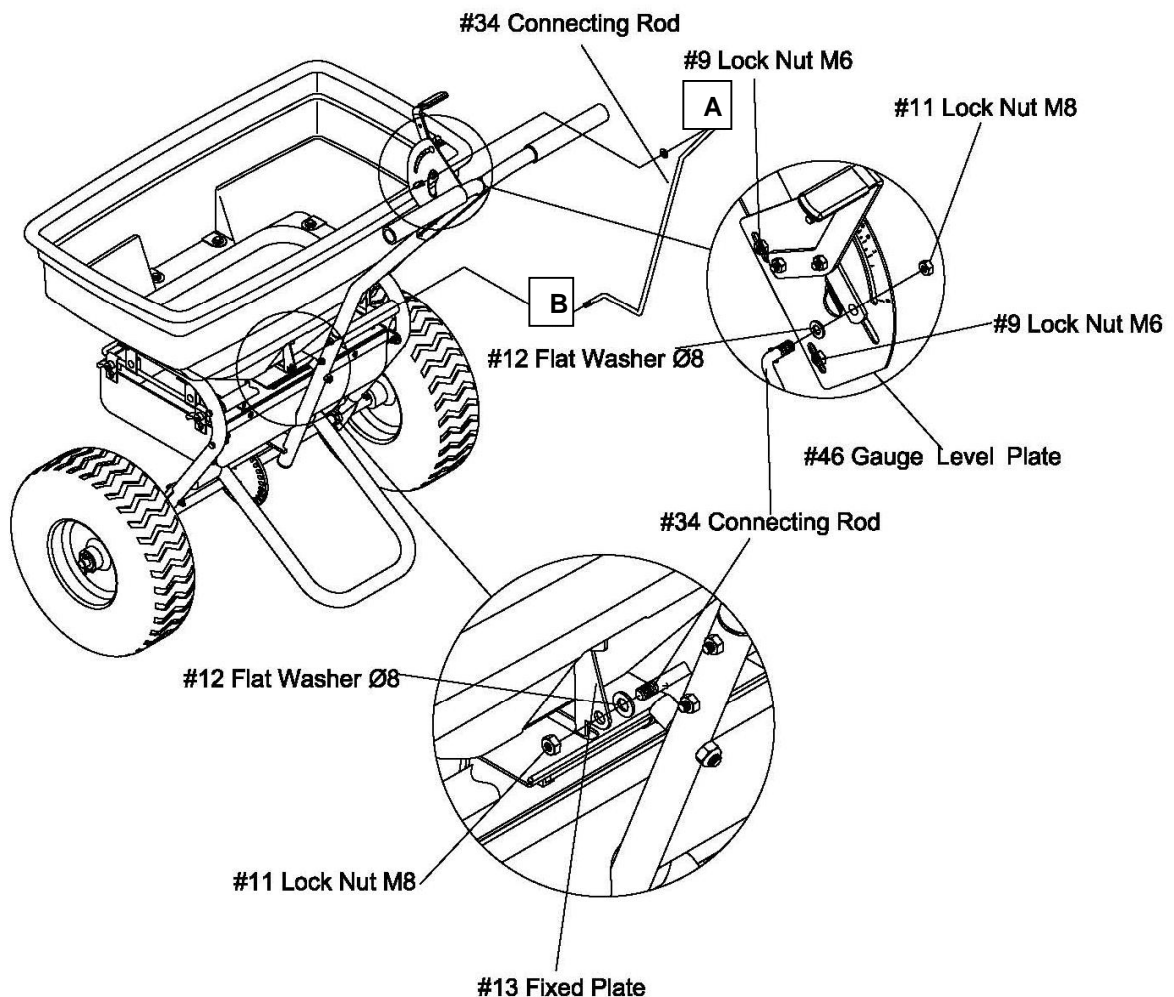

Operation Instructions

WARNING

Before using the push spreader, review the instructions below and safety information before operating. Failure to follow these instructions may result in property damage or injury to the operator or bystanders.

USING YOUR SPREADER

1. Inspect your spreader before each use. Make sure the wheels turn easily, and the gearbox moves when the spreader is pushed. The hopper should be clean and free from cracks.
2. Spreader is designed to spread a range of materials (Rock Salt, Ice Melt, Sand, Fertilizer and Grass Seed). Materials such as Powder, Manure, Top Soil and Gravel have the wrong physical characteristics and should not be used with your spreader.
3. Determine approximate size of the area to be covered and estimate amount of material required. Please refer to fertilizer manufacturer's recommendation. Break up any lumpy fertilizer as you fill the hopper.
4. Before filling the hopper, make sure that the flow control lever is in the "0" position and the flow control plate is closed.
5. Set the adjustable stop with the flow control lever always in the "0" position. Every time you are ready to stop or turn back, close the flow control plate to stop dispersing the material and continue one more stride. This reduces waste and avoids damaging the lawn with oversaturated product coverage.
6. Follow fertilizer manufacturer's recommended coverage rate for each product.
7. To maintain the same coverage when walking at a different speed, adjust the flow rate. Reduce the flow setting for slower speeds and increase the flow setting for higher speeds.
8. Keep the impeller plate horizontal when operating the spreader. Tilting the spreader will result in uneven coverage.
9. Always start walking prior to opening the closure plate.
10. Always close the flow control plate before turning or stopping the spreader.
11. If spreading material is accidentally deposited too heavily in a small area, soak the area thoroughly with a garden hose or sprinkler to prevent burning of the lawn.
12. To insure consistent coverage, make sure each broadcast pattern slightly overlaps the previous broadcast pattern.
13. When broadcasting spreading material, make sure the broadcast pattern does not hit evergreen trees, flowers or shrubs.
14. Do not over apply spreading material. Follow the recommended coverage rate for each product. Over application will lead to lawn damage and contamination.

Operation Instructions

CAUTION

The spreader settings are guidelines only. The spreader should be calibrated prior to application to ensure accuracy.

The spreader settings are based on a walking speed of 3 MPH. Walking faster or slower will alter the spread application rate. Exact rates depend upon the spreader itself and the accuracy of the person operating it.

ADJUSTING THE FLOW

1. For proper material flow settings refer to the spreading instructions section.
2. Move the bolt on flow control assembly to the proper setting and tighten.
3. Pushing the spreader forward at brisk walking speed to ensure consistent coverage of material.
4. To stop, move the flow control lever to the closed position before stopping.

CONSISTENT COVERAGE

To insure consistent coverage, make sure each broadcast pattern slightly overlaps the previous broadcast pattern as shown in figures below. Your spreader comes with adjustable deflector shields (shield down) to control the flow of Rock Salt or Ice Melt. The approximate broadcast widths for different materials are shown in the application chart.

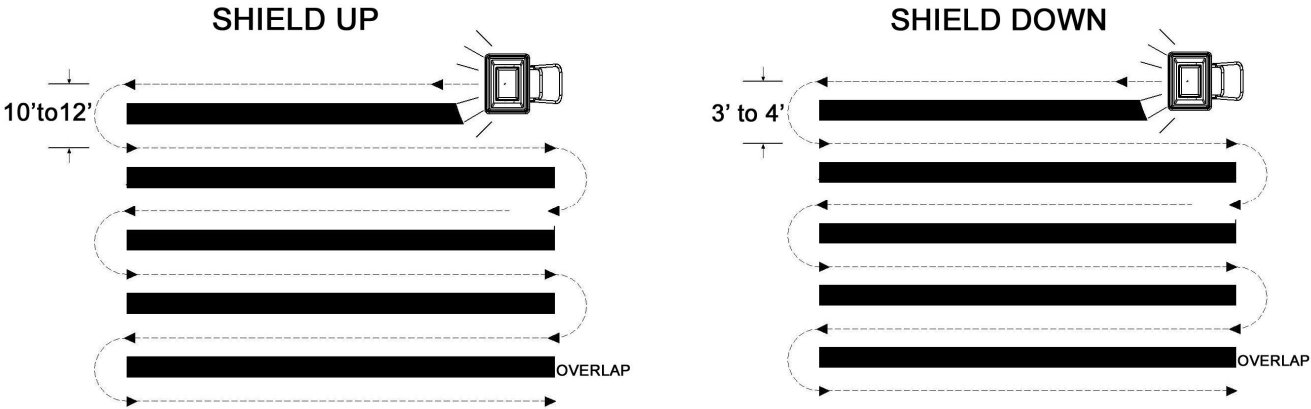

WARNING

Do not over apply spreading material. Follow the recommended coverage rate for each product. Over application will lead to damage and contamination. If spreading material accidentally hits or deposits to heavily, soak the area thoroughly with a garden hose or sprinkler to prevent burning.

Spreading Instructions

CALCULATING AMOUNT OF MATERIAL NEEDED

To calculate the amount of fertilizer you will need to cover your lawn, divide the coverage amount listed on the label by the weight of the fertilizer bag. For example a 10LB. bag of fertilizer with coverage of 10,000 square feet will distribute 1LB. of fertilizer every 1,000 square feet at full rate or 1/2LB. of fertilizer every 1,000 square feet at half rate. For pre-calculated rates see **Chart A** (Example: 25LB. bag with 15,000 sq. ft. coverage = 1.7LB./1,000 sq. ft.). Use **Chart B** to find the closest spreader setting (Example: 1.7LB./1000 sq. ft. = Spreader Setting of 12).

Chart A - Square Foot Coverage per Bag*

Weight of Bag (LBS.)	LBS/1,000 SQ FT		
	5,000 SQ FT COVERAGE	10,000 SQ FT COVERAGE	15,000 SQ FT COVERAGE
5	1.0 LB.	0.5 LB.	0.3 LB.
10	2.0 LB.	1.0 LB.	0.7 LB.
15	3.0 LB.	1.5 LB.	1.0 LB.
20	4.0 LB.	2.0 LB.	1.3 LB.
25	5.0 LB.	2.5 LB.	1.7 LB.
30	6.0 LB.	3.0 LB.	2.0 LB.
35	7.0 LB.	3.5 LB.	2.3 LB.
40	8.0 LB.	4.0 LB.	2.7 LB.
45	9.0 LB.	4.5 LB.	3.0 LB.
50	10.0 LB.	5.0 LB.	3.3 LB.

*These are only estimates actual amounts may vary.

Chart B - Spreader Settings/Spread Widths

MULTI-USAGES	LBS/1,000 SQ FT	SPREADER SETTING	● SMALL PARTICLE SPREAD	● MEDIUM PARTICLE SPREAD	● LARGE PARTICLE SPREAD
ROCK SALT ICEMELT FERTILIZER GRASS SEEDS	1	10	5-6 FT.	6-9 FT.	9-12 FT.
	2	12	5-6 FT.	6-9 FT.	9-12 FT.
	3	14	5-6 FT.	6-9 FT.	9-12 FT.
	4	15	5-6 FT.	6-9 FT.	9-12 FT.
	5	17	5-6 FT.	6-9 FT.	9-12 FT.
	6	18	5-6 FT.	6-9 FT.	9-12 FT.
	7	20	5-6 FT.	6-9 FT.	9-12 FT.
	8	23	5-6 FT.	6-9 FT.	9-12 FT.
	9	25	5-6 FT.	6-9 FT.	9-12 FT.
	10	30	5-6 FT.	6-9 FT.	9-12 FT.

*These are only estimates actual spreader settings and spread widths may vary depending on material.

Spreading Instructions

ADDITIONAL SPREADER SETTING INSTRUCTIONS

For materials that **DO NOT** use a typical 5,000 Sq. Ft, 10,000 Sq. Ft. & 15,000 Sq. Ft. coverage value.

To obtain the proper spreader settings follow the steps below:

- 1) Find the total weight in lbs. of the product from the product label on the bag of material.
- 2) Find the coverage amount in square feet that the product is rated for from the product label on the bag of material.
- 3) Divide the bag weight rated in lbs. by the square feet coverage rated on the bag.
- 4) Take this result and multiply it by 1000.
- 5) This final number is the lbs. of material to be spread per 1000 square feet.
- 6) Use the spreader setting number in Chart B for the proper setting.

As an example:

- 1) The fertilizer bag weighs 10 lbs.
- 2) The coverage value is rated at 2000 square feet.
- 3) $10 \text{ lbs.} / 2000 \text{ square ft.} = 0.005$
- 4) $0.005 \times 1000 = 5 \text{ lbs. per } 1000 \text{ sq. ft.}$
- 5) Using this number in Chart B, you would obtain a spreader setting of 17.

Chart B - Spreader Settings/Spread Widths

MULTI-USAGES	LBS/1,000 SQ FT	SPREADER SETTING	● SMALL PARTICLE SPREAD	● MEDIUM PARTICLE SPREAD	● LARGE PARTICLE SPREAD
ROCK SALT	1	10	5-6 FT.	6-9 FT.	9-12 FT.
	2	12	5-6 FT.	6-9 FT.	9-12 FT.
	3	14	5-6 FT.	6-9 FT.	9-12 FT.
ICEMELT	4	15	5-6 FT.	6-9 FT.	9-12 FT.
FERTILIZER	5	17	5-6 FT.	6-9 FT.	9-12 FT.
	6	18	5-6 FT.	6-9 FT.	9-12 FT.
GRASS SEEDS	7	20	5-6 FT.	6-9 FT.	9-12 FT.
	8	23	5-6 FT.	6-9 FT.	9-12 FT.
	9	25	5-6 FT.	6-9 FT.	9-12 FT.
	10	30	5-6 FT.	6-9 FT.	9-12 FT.

*These are only estimates actual spreader settings and spread widths may vary depending on material.

WARNING

Do not over apply spreading material. Follow the recommended coverage rate for each product. Over application will lead to damage and contamination. If spreading material accidentally hits or deposits to heavily, soak the area thoroughly with a garden hose or sprinkler to prevent burning.

Maintenance and Storage

 **WARNING**

Improper maintenance and storage of the push spreader may void your warranty.

MAINTENANCE

- After each use clean material out of hopper.
- Rinse/dry inside and outside of the spreader after each use.
- Before operating make sure the tires have the RECOMMENDED TIRE PRESSURE 30 PSI.
- Periodically check all fasteners for tightness.
- Annually clean and lightly lubricate parts.
- Never exceed load capacity rating of 125lbs it will damage the spreader.

IMPORTANT:

If a part needs replacement, only use parts that meet the manufacturer’s specifications. Replacement parts that do not meet specifications may result in a safety hazard or poor operations.

STORAGE

- Never allow material to remain in the hopper for extended periods of time.
- Before storing make sure the spreader is clean and dry for years of trouble free service.
- Store indoors or protected area during severe weather and winter months.

Specifications

Load Capacity	125lb
Spreader Type.....	Broadcast
Hopper Material	Polypropylene
Hopper Dimensions	29.5” x 16.5” x 13.4”
Overall Dimensions.....	43.3” x 31.5” x 38”
Wheel size	14”
Tire Pressure (PSI)	30
Unit Weight	18.5kg

Parts Drawing & Parts List

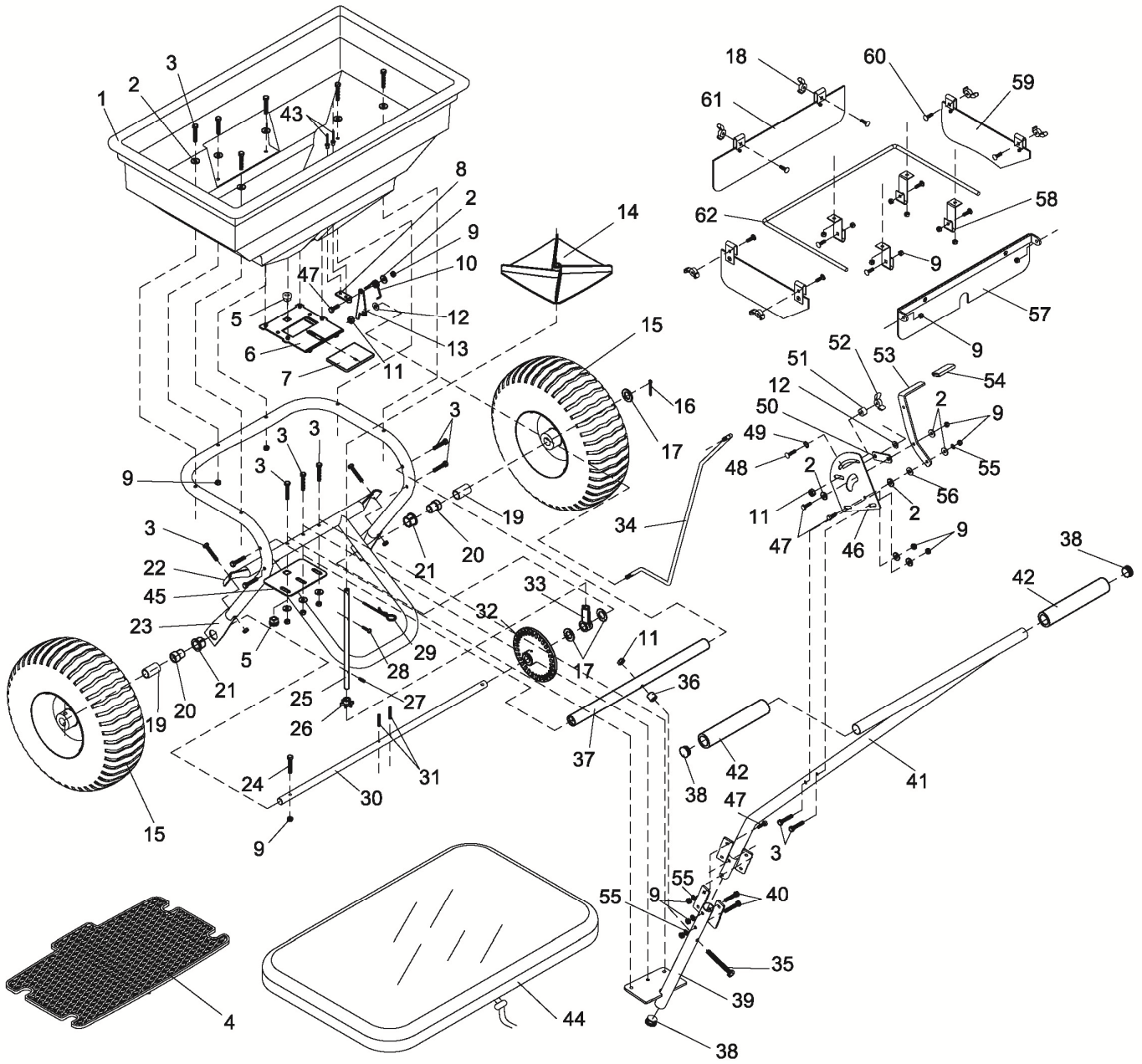

Parts Drawing & Parts List

Ref#	Description	Qty	Ref#	Description	Qty
1	Hopper Assembly	1	32	Gear	1
2	Ø6 Big Flat Washer	16	33	Swivel Axle Base	1
3	M6x40 Hex Bolt	17	34	Connecting Rod	1
4	Hopper Screen	1	35	M8x75 Hex Bolt	1
5	Swivel Axle Bushing	2	36	Wheel Bushing	1
6	Fixed Adjustable Plate	1	37	Fixed Crossover Tube	1
7	Active Adjustable Plate	1	38	End Cap	3
8	Base for Spring	1	39	Support Leg	1
9	M6 Lock Nut	29	40	M6x35 Hex Bolt	2
10	Spring	1	41	Handle Connecting Tube	1
11	M8 Lock Nut	3	42	Sponge Handle	2
12	Ø8 Flat Washer	2	43	Ø5x8 Rivet	2
13	Fixed Plate for Connecting Rod	1	44	Rain Cover	1
14	Impeller	1	45	Swivel Axle Base	1
15	Pneumatic Wheel	2	46	Gauge Level Plate	1
16	Ø5x35 Cotter Pin	1	47	M6x20 Hex Bolt	7
17	Ø16 Flat Washer	3	48	M6x25 Round Head Bolt	1
18	Stainless Steel Wing Nut	6	49	Ø8 Gear Lock Washer	1
19	Wheel Bushing	2	50	Connecting Rod Plate	1
20	Inner Axle Bushing	2	51	Spacer	1
21	Outer Axle Bushing	2	52	Wing Nut	1
22	Support Frame Assembly	1	53	Adjustable Handle	1
23	Hopper Assembling Tube	1	54	Handle Grip	1
24	M6x60 Bolt	1	55	Ø6 Spring Washer	7
25	Swivel Axle	1	56	Nylon Washer	1
26	Small Gear	1	57	Rear Back Plate	1
27	Ø3x16 Spring Pin	1	58	Hanging Plate	4
28	M4x20 Screw	1	59	Side Back Plate	2
29	R-Pin	1	60	M6x20 Round Head Bolt	10
30	Axle	1	61	Front Back Plate	1
31	Ø4x30 Spring Pin	2	62	Hanging Rod	1