

12233 Trolla

22TON LOG SPLITTER

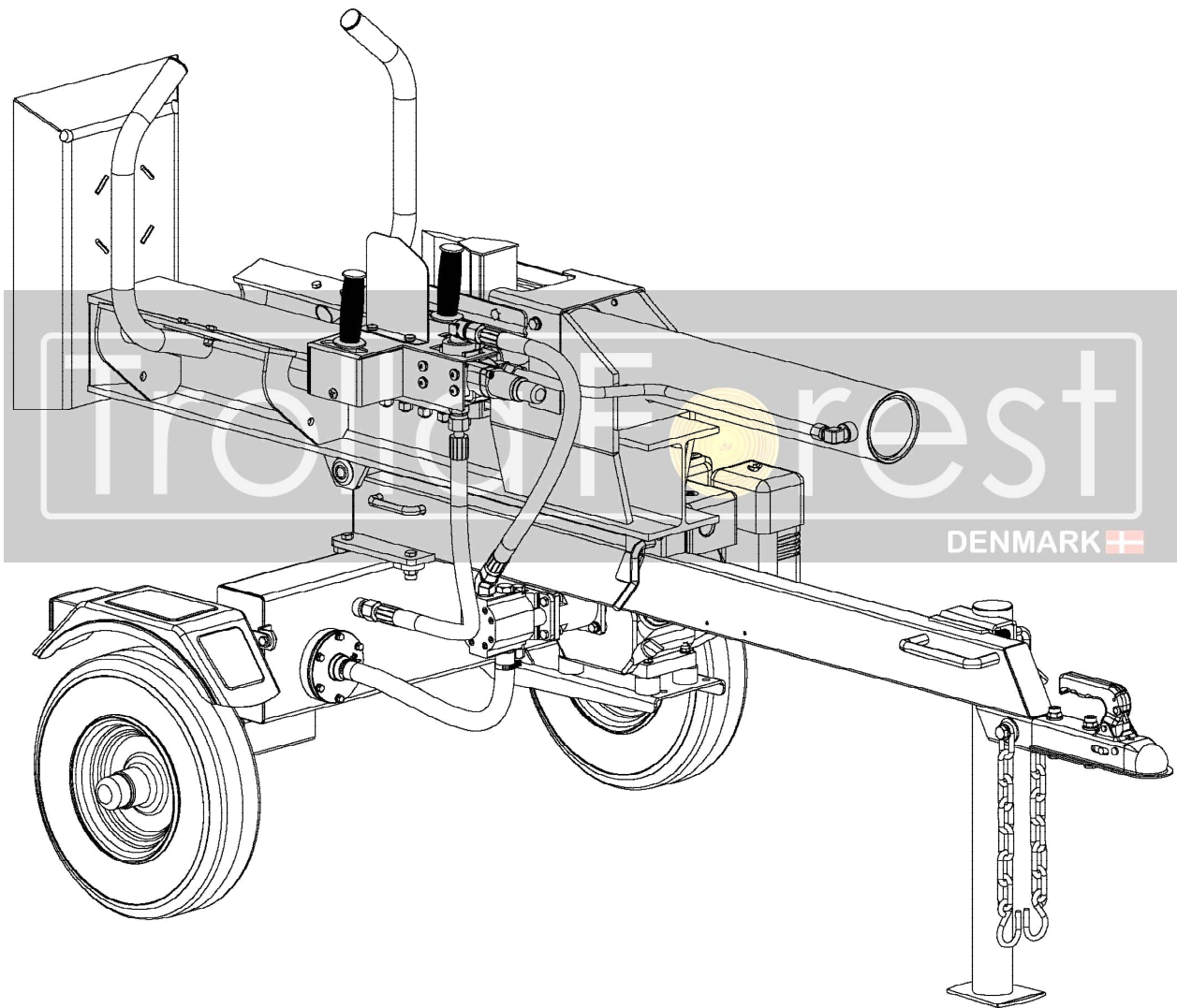

Instruction & Assembly

SAVE THESE INSTRUCTIONS FOR FUTURE REFERENCE

Table of Contents

General Warnings and Rules	3
Hazard Signal Word Definitions.....	4
Controls and Features Identification.....	5
Assembly Instructions	7
Operation Instructions	12
Maintenance and Storage	15
Troubleshooting	16
Specification.....	17
Parts Drawing & Parts List	18

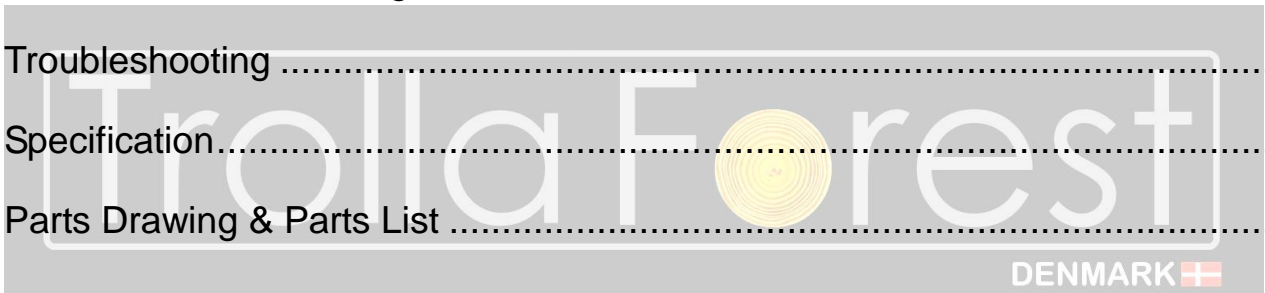

GENERAL WARNINGS

READ and UNDERSTAND this manual completely before using 22 Ton Log Splitter.

Operator must read and understand all safety and warning information, operating instructions, maintenance and storage instructions before operating this equipment. Failure to properly operate and maintain the log splitter could result in serious injury to the operator or bystanders.

Operation Warnings

- Do not at any time carry passengers, sit or stand on the log splitter.
- Do not allow children to play on, stand upon or climb on the log splitter.
- Always inspect the log splitter before using to assure it is in good working condition.
- Replace or repair damaged or worn parts immediately.
- Always check and tighten hardware and assembled parts before operation.
- Do not exceed equipment maximum load capacity of 22 tons.
- Avoid large holes and ditches when towing the equipment.
- Always operate the log splitter on clear and level ground.
- Do not operate the log splitter at night, only during daylight hours.
- Always tow at reduce speed in rough terrain, along creeks, ditches and on hillsides.
- To avoid personal injury and/or equipment damage **DO NOT EXCEED 45 MPH.**
- Always refer to the vehicle owner's manual for proper towing.
- Always secure and lock the log splitter to the vehicle hitch before towing.

Crush and Cut Hazards

- Always keep hands and feet clear from moving parts while operating the equipment.
- Always clear and keep work area clean and free of debris when operating.
- Always wear safety gear, eye protection, gloves and work boots when operating the log splitter.

WARNING

The warnings, cautions, and instructions outlined in this instruction manual cannot cover all possible conditions or situations that may occur. It must be understood by the operator that common sense and caution are factors which cannot be built into this product and must be supplied by the operator.





PROP 65 WARNING

The engine exhaust from this product contains chemicals known to the state of California to cause cancer, birth defects, or other reproductive harm.

Assembly Is Required

This product requires assembly before use. See "Assembly" section for instructions. Because of the weight and/or size of the log splitter, it is recommended that another adult be present to assist with the assembly. **INSPECT ALL COMPONENTS** closely upon receipt to make sure no components are missing or damaged.

Hazard Signal Word Definitions

	<p>This is the safety alert symbol. It is used to alert you to potential personal injury hazards. Obey all safety messages that follow this symbol to avoid possible injury or death.</p>
	<p>DANGER indicates an imminently hazardous situation which, if not avoided, will result in death or serious injury.</p>
	<p>WARNING indicates a potentially hazardous situation which, if not avoided, could result in death or serious injury.</p>
	<p>CAUTION indicates a potentially hazardous situation which, if not avoided, may result in minor or moderate injury.</p>
	<p>CAUTION used without the safety alert symbol indicates a potentially hazardous situation which, if not avoided, may result in property damage.</p>

ABOUT YOUR 22 TON LOG SPLITTER

This hydraulic log splitter has a heavy-duty steel construction and 22 tons of ram force. When there's work to be done, you need outdoor power equipment you can rely on, this log splitter will get the job done fast. It is designed to work in both horizontal and vertical position. It is easy to tow, easy to use and maintain. Never exceed the rated capacity of 22 tons when operating the log splitter.

Technical specifications on the log splitter are provided in the "Specifications" section of this manual.

Controls and Features Identification

Read this owner's manual before operating the equipment. Familiarize yourself with the location and function of the controls and features. Save this manual for future reference.

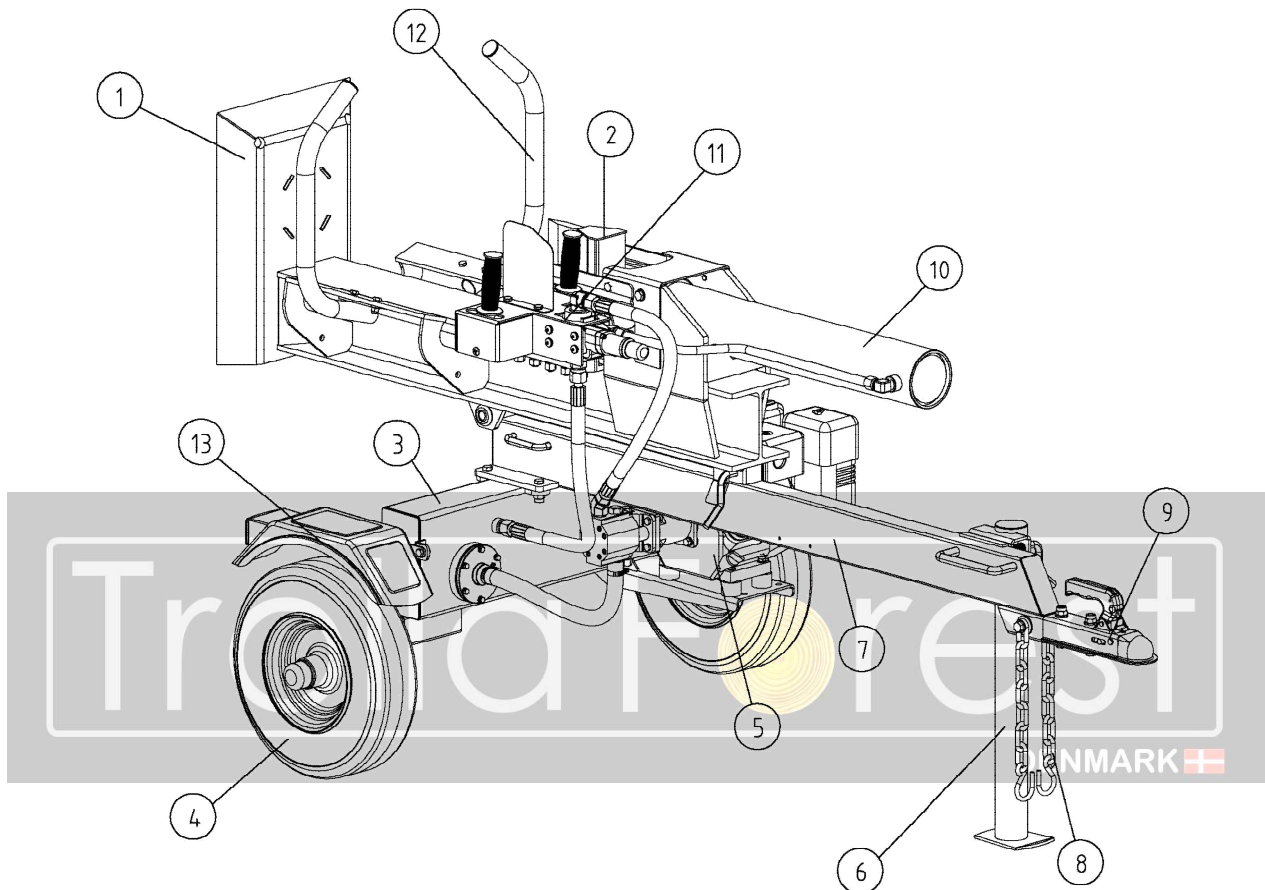

- 1) **Beam** - 6" extra wide flange.
- 2) **8" Wedge** - Features wedge wings and tapered ends making splitting easier.
- 3) **Oil Tank**
- 4) **Tires** - Maximum rated towing speed is 45 MPH.
- 5) **Engine** - Air cooled 208cc engine powers the hydraulic pump
- 6) **Support Leg**- Supports the log splitter while operating.
- 7) **Tow Bar**- Move with ATV & Lawn/Garden Tractor
- 8) **Safety Chains** - Safety feature to prevent loss of log splitter while towing.
- 9) **50mm Coupler** – Attaches the log splitter to the 50mm ball.
- 10) **Hydraulic Cylinder** –4" bore and 23-1/4" stroke, rated to 3600 psi.
- 11) **Control Valve Lever** – Controls the forward and backward movement of splitting wedge
- 12) **Log Cradle**
- 13) **Fender**



CAUTION

Read and follow all instructions for assembly and operation. Failure to properly assemble this equipment could result in serious injury to the user or bystanders, or cause equipment damage.



Engine Shipped Without Oil.

Before starting engine, fill with SAE 10W-30 motor oil.
See engine manual for engine oil capacity.

Hydraulic Oil Tank is Shipped Without Oil.

When adding oil verify the oil level using the Oil filter/Dip Stick on the top of hydraulic oil tank if marking is not shown fill to the L line.

Inspect all Log Splitter Components.

If you have damaged components: Contact the freight company that delivered the log splitter and file a claim.

22 TON LOG SPLITTER ASSEMBLY

Set the shipping crate on a solid flat surface and carefully remove the lid. Use two people and take all parts out of the shipping crate and inspect the components to ensure there are no missing pieces before starting to assemble the log splitter follow steps 1 through 10.

TOOLS REQUIRED

- Rubber or Wooden Hammer
- 13mm, 16mm, 17mm, 18mm, 19mm, 24mm, 27mm Wrenches
- Large Adjustable Wrench
- Phillips Screwdriver
- Pliers



DENMARK 

Assembly Instructions

STEP 1: Wheel Assembly

1. Attach the wheels (#4) to the wheel stand secure using flat washer $\text{\O}20$ (#6), thin hex slotted nut M20x1.5 (#8) and cotter pin $\text{\O}4 \times 36$ (#5). Install the axle cap (#7) on the end using rubber hammer.

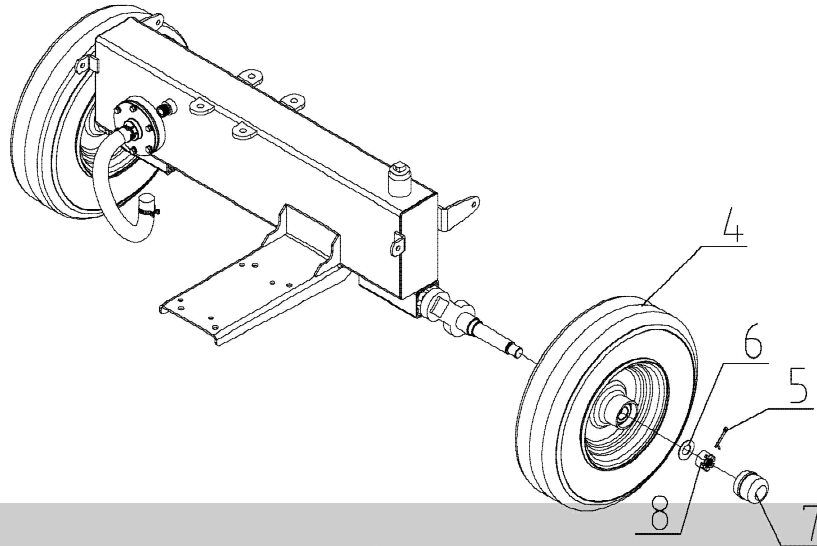

STEP 2: Attach Tow Bar and Front Support Leg

1. Attach the tow bar (#2) to the oil tank using hex bolt M12x35 (#35), flat washer $\text{\O}12$ (#20) and lock nut M12 (#25).

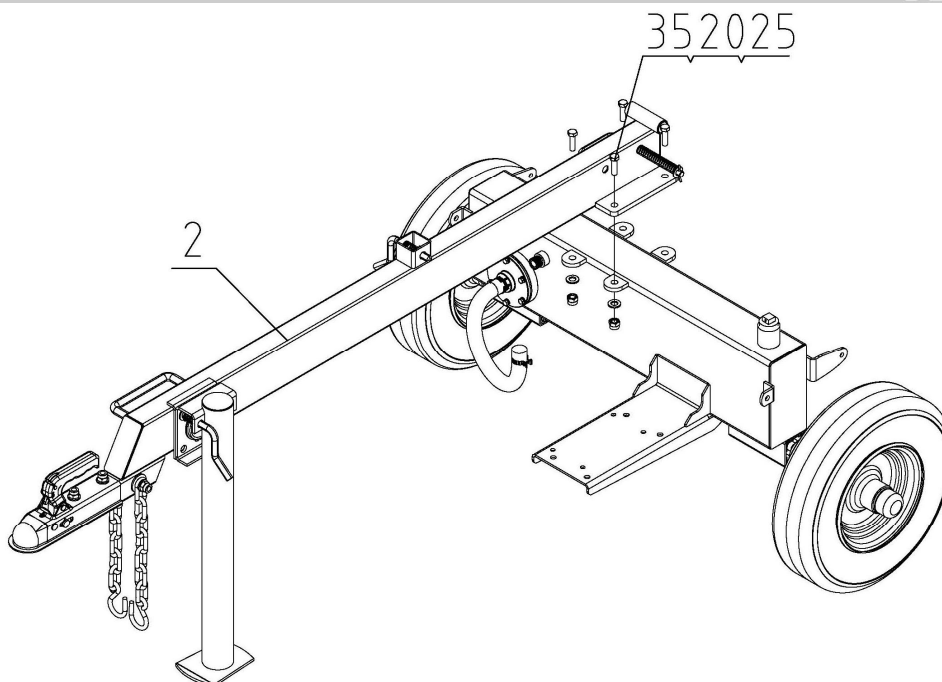

STEP 3: Attach Beam to the Tow Bar

1. Attach the beam to the tow bar using Hitch Pin (#50) and R Pin (#71).
2. Attach reversing valves outlet tube (#42) to oil tank connector, sealing with O ring 14×2.5 (#33)

Note: Tighten oil pipe connector between torque of 80-90N • m

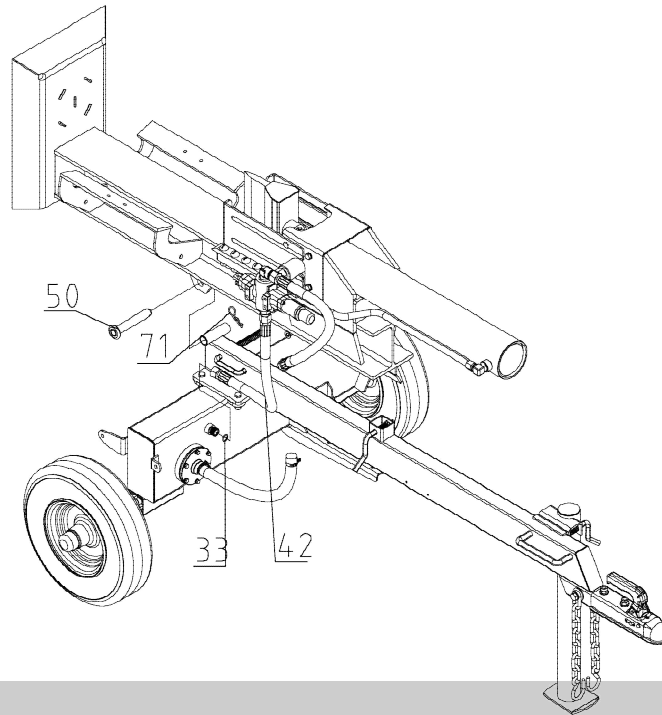

STEP 4: Attach Engine and the Oil Pipe

1. Attach the engine to the wheel stand using polyurethane block (#12) and big flat washer Ø10 (#58), hex bolt M8x65 (#36), flat washer Ø8 (#37), lock washer Ø8 (#57), nylon lock nut M8 (#38).
2. Attach the oil pipe (#43) to the gear pump oil inlet connector, positioning by clamp (#44).
3. Attach the high pressure oil pipe (#39) to the gear pump oil outlet connector, sealing with O ring 11.2 ×2.4 (#32)

Note: Tighten oil pipe connector between torque of 80-90N • m

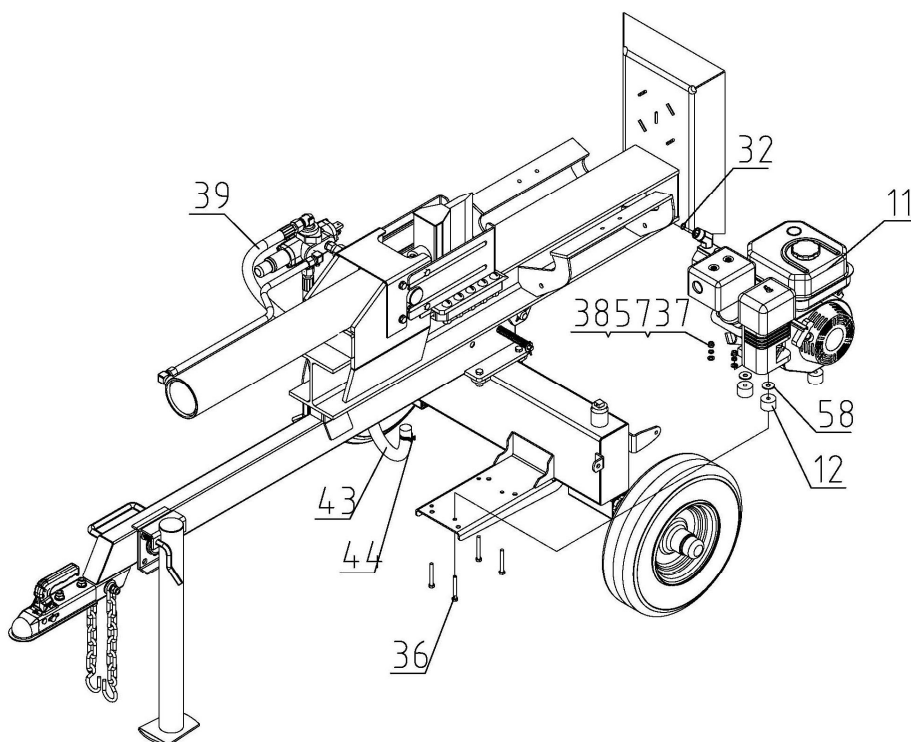

STEP 5: Attach the Handles

1. Attach the handles to the control valve, using pin $\text{Ø}5 \times 26$ (#83), cotter pin $\text{Ø}2 \times 10$ (#84), inner hex cylindrical head screw M8x16 (#81), spring washer $\text{Ø}8$ (#57).

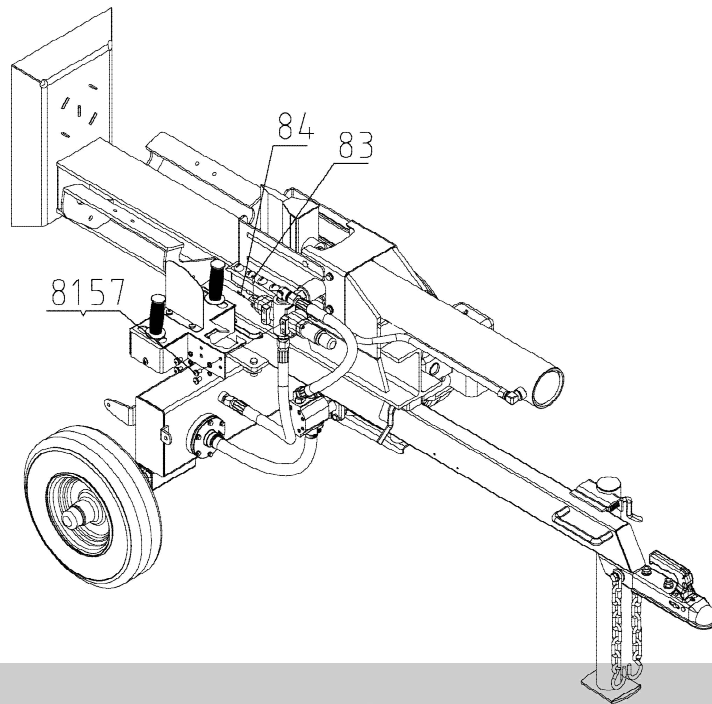

STEP 6: Attach the Log Cradle

1. Attach log cradle (53) using hex bolt M8x25 (#69), flat washer $\text{Ø}8$ (#37), nylon lock nut M8 (#38).

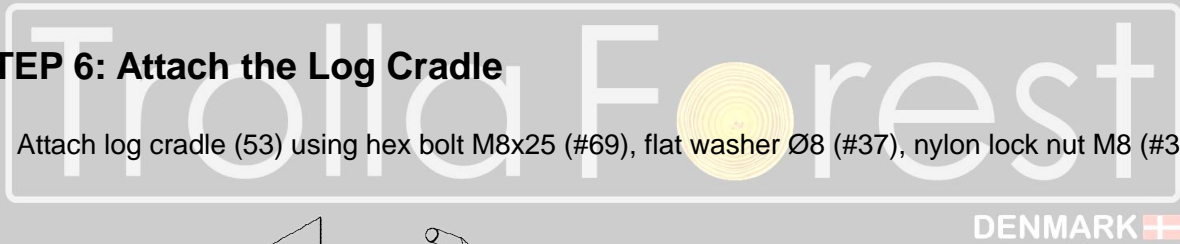
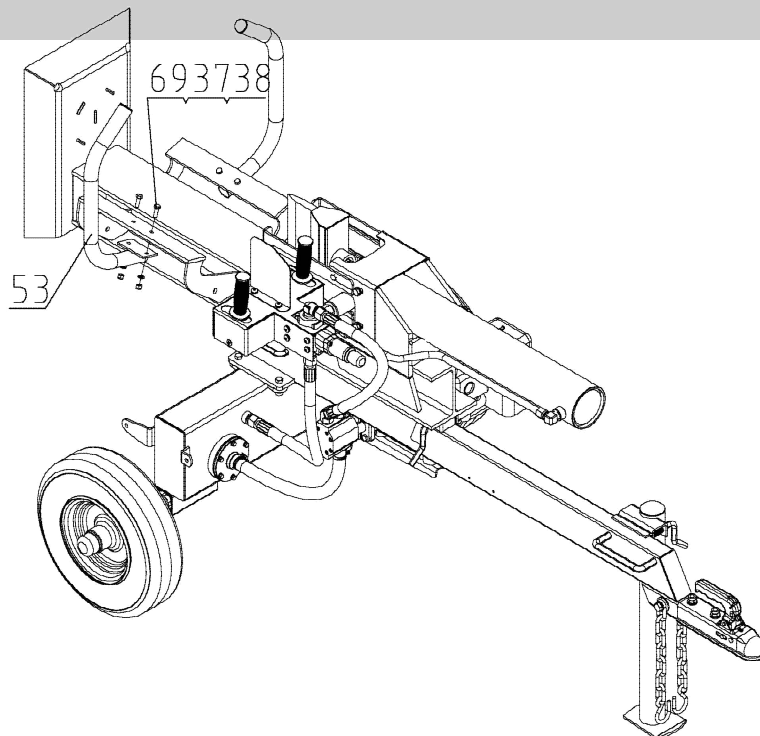

STEP 7: Add the Fenders

1. Attach the fenders (#89 & #90) to the oil tank, using hex bolt M8x25 (#69), flat washer Ø8 (#37), lock washer Ø8 (#57) and nylon hex nut M8 (#38).

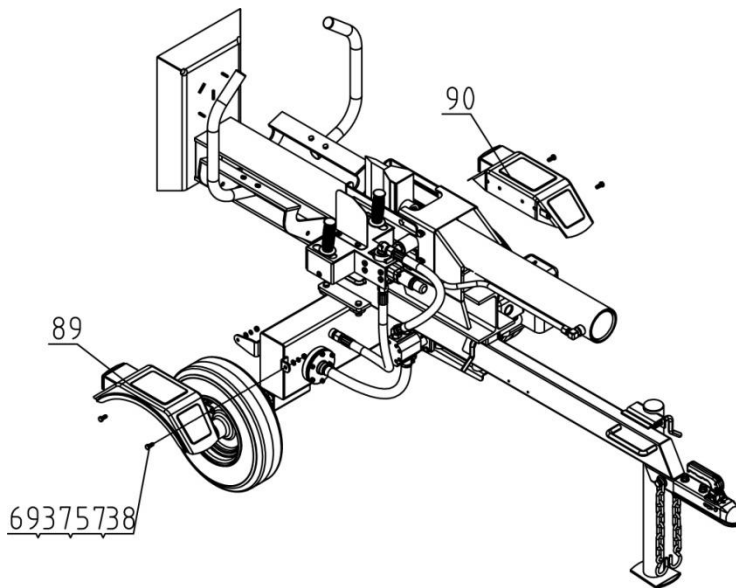

STEP 8: Add Engine Oil

1. Make sure the log splitter is on a level surface.
2. Remove oil fill cap/dipstick to add oil.
3. Refer to the separate owner's engine manual for the amount needed of SAE10W-30 engine oil; replace oil fill cap/dipstick.
4. Check engine oil level daily and add as needed.

DENMARK 

NOTE: During the break-in period check the engine oil level often.



CAUTION

DO NOT attempt to crank or start the engine before it has been properly filled with the recommended type and amount of oil. Damage to the log splitter as a result of failure to follow these instructions will void your warranty.

STEP 9: Add Gasoline to the Engine

1. Use only clean, fresh, regular unleaded fuel with a minimum 86 octane rating.
2. DO NOT mix oil with fuel.
3. Remove the fuel cap and slowly add fuel to the tank. DO NOT overfill allow approximately ¼ inch of space for fuel expansion.
4. Screw on the fuel cap and wipe away any spilled fuel.

 **DANGER**

Log splitter engine exhaust contains carbon monoxide, a colorless, odorless, poison gas. Breathing carbon monoxide will cause nausea, dizziness, fainting or death. If you start to feel dizzy or weak, get to fresh air immediately.

Operate log splitter outdoors only in a well ventilated area.

DO NOT operate the log splitter inside any building, enclosure or compartment.

DO NOT allow exhaust fumes to enter a confined area through windows, doors, vents or other openings.

DANGER CARBON MONOXIDE, using a log splitter indoors **CAN KILL YOU IN MINUTES**.

 **CAUTION**

Fuel and fuel vapors are highly flammable and extremely explosive.

Fire or explosion can cause severe burns or death.

Unintentional startup can result in entanglement, traumatic amputation or laceration.

Only use regular unleaded gasoline with a minimum 86 octane rating.

DO NOT mix oil and gasoline together.

Fill tank approximately ¼" below the top of the tank to allow for fuel expansion.

DO NOT fill fuel tank indoors or when the engine is running or hot.

DO NOT light cigarettes or smoke when filling the fuel tank.

STEP 10: Add Hydraulic Oil

1. The log splitter needs to be on a flat, level surface before adding the hydraulic oil.
2. Remove the oil cap from the hydraulic oil tank.
3. Add approximately 3 gallons of hydraulic oil, 10W AW, AW-32, ASLE H-150, ISO 32, Universal Hydraulic Fluid or Dexron III Transmission Fluid.
4. Check the hydraulic oil level.
5. Start engine and use the control lever to extend and retract wedge several times to remove air from the lines.
6. With the wedge retracted, check hydraulic oil level again and fill if necessary.

 **WARNING**

DO NOT remove the hydraulic oil fill cap when the engine is running or hot. Hot oil can escape causing severe burns. Always allow the log splitter to cool completely before removing the hydraulic oil cap.

High fluid pressure and temperatures are created in the hydraulic log splitters. Hydraulic fluid will escape through a pin-size hole opening and can puncture skin and cause severe blood poisoning.

Inspect hydraulic system regularly for possible leaks. **Never check for leaks with your hand while the system is pressurized. Seek medical attention immediately if injured by escaping fluid.**

Make sure all fittings are tight and secure before applying pressure. Relieve system pressure before servicing.

Make sure the hydraulic hoses do not touch any hot surfaces or cutting areas.

Hoses need to be positioned where they are clear from the engine and cutting wedge. To avoid serious bodily injury always inspect the hoses before operating the log splitter.

Operation Instructions

WARNING

Before operating or using the log splitter, review the instructions below and all safety information. Failure to follow these instructions may result in property damage or injury to the operator or bystanders.

WARNING

ALWAYS use the log splitter for its intended use.
ONLY use the log splitter to split wood logs, length wise with the grain.
NEVER modify, alter or change the log splitter in anyway, modifications will void the warranty.
NEVER attach a rope, cable or other device to the control lever on the log splitter.
ONLY operate the log splitter in daylight.
NEVER leave the log splitter unattended while the engine is running.
DO NOT change the splitting position with the engine running. Contact with the muffler can cause serious burns.
ALWAYS make sure the beam is in the locked position.
DO NOT let the beam drop as it could crush fingers or cause damage to the log splitter.
NEVER operate or let anyone else operate, the log splitter while under the influence of alcohol, drugs, or medication.

USING YOUR LOG SPLITTER

1. DO NOT at any time carry passengers, sit or stand on the log splitter.
2. Check the hydraulic oil level and visually inspect all hoses and attachments for problems.
3. Inspect the engine and make sure the engine oil level is correct.
4. Before towing the log splitter the tires need to be fully inflated.

DENMARK 

TIRE WARNING

DO NOT over inflate tires. Serious injury can result if tires explode
DO NOT tow the log splitter if the tires are worn or will not hold air.
DO NOT exceed the maximum 45 MPH towing speed.

5. Refer to the vehicle owner's manual for proper safety and towing instructions.

TOWING WARNING

Serious injury or death can occur if towing safety rules are not followed.
Always check the ball coupler and wheels to make sure all hardware is secure before towing.
Before towing a long distance check to make sure the axle nuts and pins are tight and securely in place.
Always use safety chains, secure and lock the log splitter to the vehicle hitch before moving.
Drive safely. Be aware of the added length of the log splitter.
Never exceed the maximum travel speed of 45 mph.
Never ride or transport cargo on the log splitter.
Turn off the vehicle before leaving the log splitter unattended.
Block the log splitter wheels to prevent unintended movement.

- The log splitter must have at least seven feet of clearance from combustible material. It needs to be on a dry and level surface with good footing. Do not work on mud, ice, brush or snow. When using the log splitter the work zone must be maintained at all times.

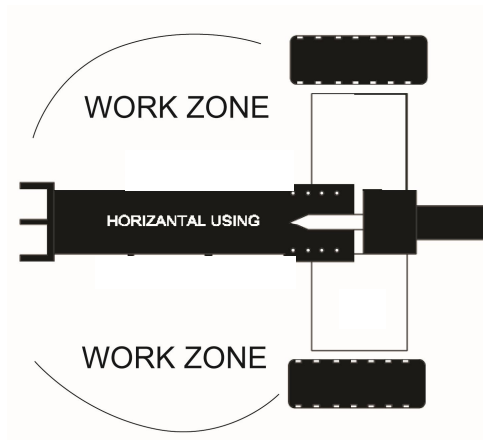

NOTE: Serious accidents can happen when other people are allowed inside the work zone. Keep everyone else outside the work zone while operating the control lever.

- Always wear safety gear, eye protection, gloves and work boots when operating the log splitter
- Start the engine and make sure the log splitter is on level ground before operating.

NOTE: The hydraulic oil needs to be above 10°F (-12C°) before starting the engine. Cold hydraulic oil can damage the hydraulic pump. If outdoor air temperature is below 32°F (0C°) allow the log splitter to warm up by extending and returning the wedge several times before splitting wood.

- Put both support legs in the down position to prevent the log splitter from moving during operation and block both tires.
- Set the log splitter in horizontal position.

NOTE: HORIZONTAL position is used for lighter logs that can easily be loaded onto the beam. Back injury can result from lifting logs onto the log splitter if proper lifting techniques are not used.

11. Load a log onto the beam against the endplate (Max Log Length-25")

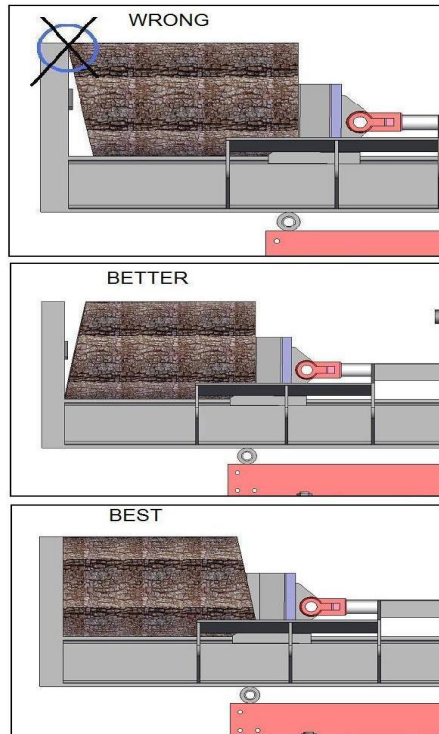

12. Make sure hands are clear from the wedge and crush hazard areas.



CRUSH WARNING

Wedge can cut through skin and break bones. Keep both hands away from wedge and beam slide. Serious accidents can happen when other people are allowed inside the work zone. Keep everyone else out of the work zone while operating control lever.
DO NOT wear loose clothing. It can get tangled in moving parts of log splitter.
Only use the log splitter in daylight so you can see what you are doing.

13. Push control lever FORWARD by one hand to split the log.

14. Push control lever BACKWARD by one hand to return wedge to its original position



CAUTION

If a log gets stuck, embedded or will not split completely, push the control lever in the reverse direction and allow the splitter to strip the log from the wedge.

If the log still remains stuck, embedded or will not split, turn the machine off and use a sledge hammer and crow bar to remove the log.

ALWAYS keep hands clear of the log and wedge while it is retracting.

15. Always keep work zone clean and free of split wood and debris.

Maintenance and Storage



WARNING

Improper maintenance and storage of the log splitter may void your warranty.

MAINTENANCE

- Before performing maintenance, the log splitter must be placed in maintenance mode. Turn off the engine and move the control lever forward and backwards to relieve the hydraulic pressure.
- After performing any maintenance, make sure all guards, shields and safety features are put back in place before operating the log splitter.
- Before operating make sure the tires have the **RECOMMENDED TIRE PRESSURE**.
- Regularly grease axle and wheel bearing area or when needed.
- After the wheel bearings have been greased make sure the axle nuts and pins are in place and secure.
- Periodically check all fasteners and hoses for tightness and leaks.
- Annually clean and lightly lubricate all moving parts or when needed.
- Use a glossy enamel spray paint to touch up scratched or worn painted metal surfaces.
- Never exceed load capacity rating of 22 tons it will damage the log splitter.

What	When	How
Hoses	Each Use	Inspect hoses for exposed wire mesh and leaks. Replace all worn or damaged hoses before starting the engine.
Hydraulic Fittings	Each Use	Inspect fittings for cracks and leaks. Replace all damaged fittings before starting the engine.
Nuts and Bolts	Each Use	Check for loose bolts, tighten before operating.
Beam	Each Use	Apply grease to beam surface.
Moving Parts	Each Use	Clear debris from log splitter.

Refer to the Engine Owner's Manual for engine maintenance.

IMPORTANT:

If a part needs replacement, only use parts that meet the manufacturer's specifications. Replacement parts that do not meet specifications may result in a safety hazard or poor operations.

STORAGE

- Before storing make sure the log splitter is clean and dry for years of trouble free service.
- Lightly lubricate all log splitter surfaces and moving parts to prevent rust.
- Store indoors or protected area during severe weather and winter months.

Troubleshooting

Problem	
Cylinder rod will not move	SOLUTION: A,D,E,H,J
Slow cylinder rod speed when extending or retracting	SOLUTION: A,B,C,H,I,K,L
Wood will not split or splits extremely slowly	SOLUTION: A,B,C,F,I,K
Engine bogs down during splitting	SOLUTION: G,L
Engine stalls under low load condition	SOLUTION: D,E,L,M
Cause	Solution
A -Insufficient oil to pump	Check oil level in reservoir
B -Air in oil	Check oil level in reservoir
C -Excessive pump inlet vacuum	Check pump inlet hose for blockage or kinks
D -Blocked hydraulic lines	Flush and clean the splitter hydraulic system
E -Blocked control valve	Flush and clean the splitter hydraulic system
F -Low control valve setting	Adjust control valve with a pressure gauge
G -High control valve setting	Adjust control valve with a pressure gauge
H -Damaged control valve	Return control valve for authorized repair
I -Internal control valve leak	Return control valve for authorized repair
J -Internal cylinder leak	Return cylinder for authorized repair
K -Internally damaged cylinder	Return cylinder for authorized repair
L -Engine Control out of adjustment	Adjust idle control nuts
M -Engine is loaded during idle down mode	Use shorter log length (25" or less) to allow engine to speed up before contact.

Specifications

Max. Force	19.8MT (22 US Ton)
Cycle Time	15s
Hydraulic Tank Capacity	14.5L
Max. Log Length	25"
Hydraulic Cylinder	4" x 23-3/16"
Max. Pressure	25Mpa (3600 psi)
Gear Pump	11GPM, 2-Stage
Max. Towing Speed	45 MPH
Wheel Size	16inches(4.8 x 8)
Engine	6.5HP, 3600RPM
Overall Size	228x122x119cm(89.8"x48"x46.9")
Net Weight	495.6LB

NOTE: For Engine Details Refer to the Engine Owner's Manual.

Parts Drawing & Parts List

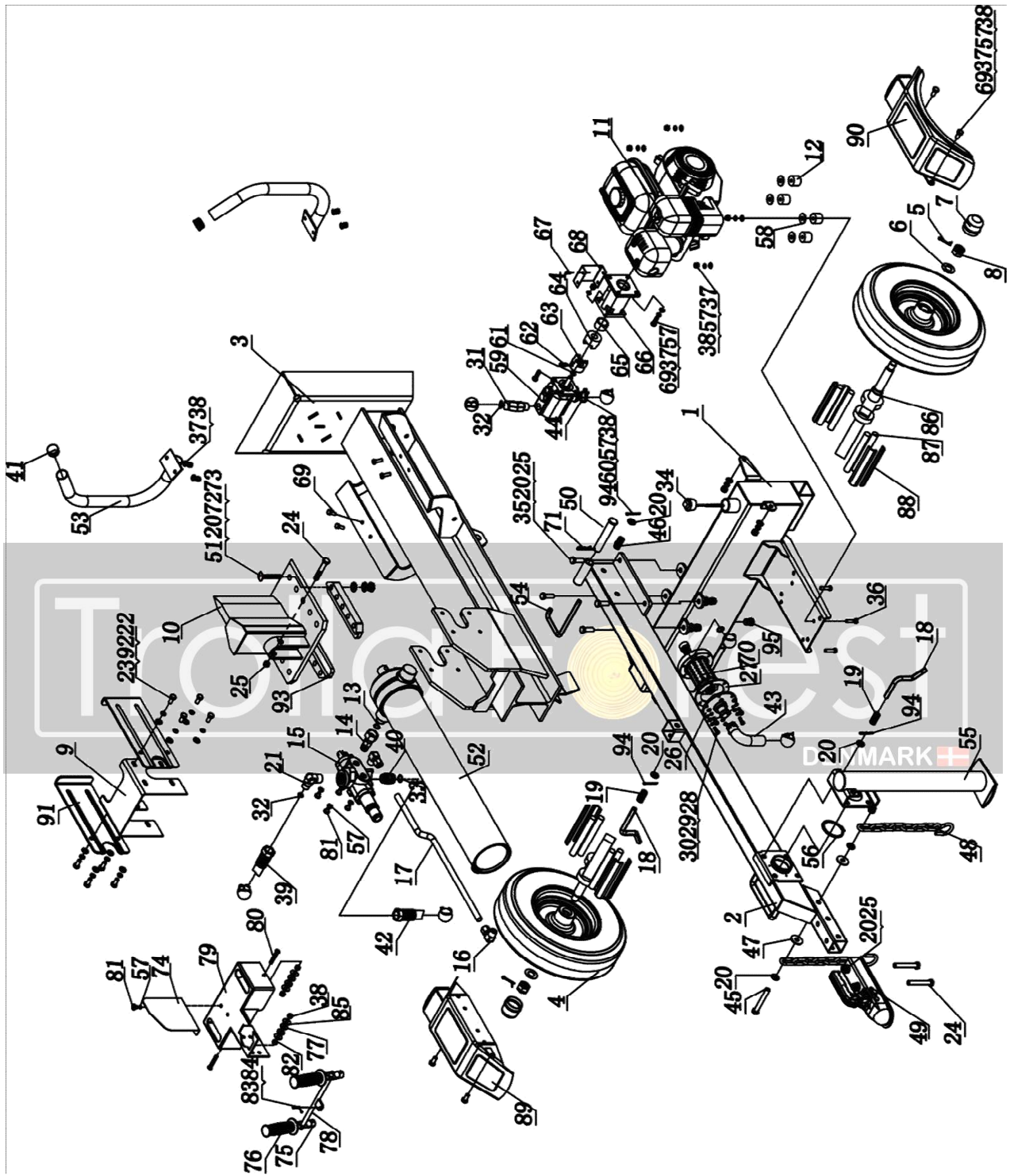

Parts Drawing & Parts List

Ref#	Drawing No.	Description	Qty
1	LSE22-02000	Oil Tank	1
2	LSE22-03000	Tow Bar	1
3	LSE22-01000	Beam	1
4	LSP25-14000	Wheel	2
5	9404-04036-DX	Cotter Pin 4x36	2
6	9301-20000-DX	Flat Washer Ø20	2
7	LSP25-00009-DX	Axle Cap	2
8	LSP25-00020-FH	Hex Slotted Thin Nut	2
9	LSM30-00003	Cylinder Cover	1
10	LSE22-04000	Wedge Slide	1
11	LSP25-10001	6.5HP Engine	1
12	LSP25-00025	Polyurethane Block	4
13	9901-16*2.5	O Ring Ø16x2.5	1
14	LSP25-17000	Combination Connector	1
15	LSE22-06001	Control Valve	1
16	LSP25-06000	Cutting Sleeve Connector	2
17	LSE22-00001-DX	Metal Hydraulic Hose	1
18	LSP25-00008-DX	Safety Pin	2
19	LSP25-00003-DX	Spring	2
20	9301-12000-DX	Flat Washer Ø12	21
21	LSE22-00006-DX	Right Angle Connector	1
22	9301-10000-DX	Flat Washer Ø10	8
23	9101-10025-DX	Hex Bolt M10x25	8
24	9101-12070-DX8.8	Hex Bolt M12x70	3
25	9206-12000-DX	Nylon Lock Nut M12	8
26	LSP25-15000-DX	Filter Fix Plate	1
27	LSP25-00021	Rubber Washer	1
28	9301-06000-DX	Flat Washer Ø6	6
29	9306-00006-DX	Lock Washer Ø6	6
30	9101-06020-DX	Hex Bolt M6x20	6
31	LSE22-00004-DX	Gear Pump Joint	1
32	9901-11.2*2.4	O Ring Ø11.2x2.4	2
33	9901-14*2.5	O Ring Ø14x2.5	2
34	LSP25-13000	Oil Bolt	1
35	9101-12035-DX	Hex Bolt M12x35	4
36	9101-08065-DX	Hex Bolt M8x65	4
37	9101-08000-DX	Flat Washer Ø8	16

Parts Drawing & Parts List

Ref#	Drawing No.	Description	Qty
38	9206-08000-DX	Nylon Lock Nut M8	18
39	LSE22-00002	Hydraulic Hose(valve-gear pump)	1
40	LSE22-00005-DX	Connector	1
41	LSE22-00011	Plug	2
42	LSE22-00003	Hydraulic Hose(valve-oil tank)	1
43	LSA22-00007	Oil Pipe	1
44	LSP25-00011	Clamp	2
45	9101-12090-DX	Hex Bolt M12x90	1
46	LSE22-00008-DX	Spring	1
47	LSP25-00015-DX	Thick Washer	2
48	LSP25-11000-DX	Chain	2
49	Z104	50mm Coupler	1
50	LSP25-05000-DX	Hitch Pin	1
51	919904-12055-DX12.9	Slotted Screw	10
52	LSE22-07000	Cylinder	1
53	LSE22-08000	Log Cradle	2
54	LSE22-00007-DX	Safety Pin	1
55	LSE22-05000	Front Support Leg	1
56	9304-62000-FH	Steel Wire Snap Ring for Shaft	1
57	9206-08000-DX	Lock Washer Ø8	22
58	9302-10000-DX	Big Flat Washer Ø10	4
59	LSP25-10007	Gear Pump	1
60	9101-08030-DX	Hex Bolt M8x30	4
61	LSP25-10008-FH	Wire Snap Rings for Shaft	1
62	9121-06010-FH	inner Hex Cone Point Set Screw M6x10	1
63	LSP25-10003	Gear Pump Coupler	1
64	LSP25-10002	Engine Coupler	1
65	LSP25-10004-DX	Engine Bushing	1
66	LSP25-1005	Gear Pump Stand	1
67	9101-05010-DX8.8Q	Hex Bolt M5x10	4
68	LSP25-10006	Coupler Cover	1
69	9101-08025-DX8.8Q	Hex Bolt M8x25	12
70	LSP25-00022	Filter	1
71	LSP25-00012-DX	R Pin	1

Parts Drawing & Parts List

Ref#	Drawing No.	Description	Qty
72	9306-12000-DX	Lock Washer Ø12	10
73	9210-12000-DX8.8	Thick Hex Nut M12	10
74	M3VxxA-00002	Cover plate	1
75	N290-22001	Handle	2
76	Z330-00002	Plastic Handles Gloves	2
77	C130-00004	Nylon Washer	4
78	M3VxxA-01000	Connecting Pipe	1
79	LSE22-06100	Frame	1
80	9110-08050-DX	Screw M8x50	2



81	9105-08016-FH	Screw M8x16	6
82	9101-08000-DX	Hex Nut M8	2
83	9403-05026-DX	Hinge Pin Ø5X26	1
84	9404-2X10/DX	Cotter Pin 2x10	1
85	9302-08000-DX	Big Flat Washer Ø8	4
86	LSE22-09000	Wheel Axle	2
87	LSE22-00013	Rubber Rod	8
88	LSE22-00012	Rubber Rod Plate	8
89	LSP30-05000	Left Fender	1
90	LSP30-06000	Right Fender	1
91	LSE22-00010	Ejector Head	2
92	9306-10000-DX	Spring Washer Ø10	8
93	LSA22-03001	Wedge Spacer	2
94	9404-03030-DX	Cotter Pin Ø 3x30	3
95	LSP25-00010-DX	Oil Plug	1

